



100091737_N370170493

noken
PORCELANOSA BATHROOMS

Carretera CV-20 km.2 · 12540 Vila-real · Castellón · Spain
Tel: +34 964 50 64 50 - Fax: +34 964 50 67 93
e-mail: noken@noken.com · www.noken.com

ADA
COMPLIANT

NK ONE



- Please read these instructions carefully before starting installation and retain for future reference. Please leave these instructions with the end user.
- Remove all packaging and check the product for missing parts and damages before starting the installation.
- Any alterations made to this product and its fittings may infringe the water regulations and will invalidate the guarantee.
- We strongly recommend the use of a qualified and registered plumber.
- In new buildings it is recommended to water fill the traps to ensure toxic gases do not corrode the surface of the taps and toilet seats. It is recommended that the room is well ventilated.
- Thoroughly flush through all pipe work prior to the installation of terminal appliances, e.g. Shower heads, taps, inlet valves etc.
- Factory fitted components such as inlet and outlet valves should be checked for position and tightness, they may have loosened in transit. Check the operation of the valves.
- Periodic cleaning and maintenance should be used to avoid the build up of damaging lime scale deposits.
- Bathroom harsh cleaning agent residuals may damage components made of metal, glass and/or chromed parts such as, seat hinges, trim plates, push buttons, etc...

Lea atentamente estas instrucciones antes de comenzar la instalación.

- Compruebe el producto por si faltasen piezas o estuviesen dañadas.
- Cualquier alteración que se realice al sanitario invalidaría la garantía.
- Le recomendamos la instalación por parte de personal cualificado.
- En nuevas construcciones se deben llenar los sifones de inodoros, lavabos y bidets de agua para evitar que la grifería y los asientos se oxiden o amarilleen por el efecto de la subida de gases corrosivos. Se recomienda que el espacio esté muy aireado.
- Purgar las tuberías antes de la instalación.
- Compruebe el funcionamiento del mecanismo de la cisterna del inodoro.
- Gracias a un cuidado periódico se puede evitar la formación de restos calcáreos.
- Residuos de productos de aseo y limpieza pueden dañar las piezas metálicas, cromadas y/o de vidrio de los sanitarios, como bisagras, embellecedores, pulsadores, etc...

- Lire attentivement cette notice avant de commencer l'installation

- Vérifier si certaines pièces sont manquantes ou abîmées.
- Toute altération qui sera effectuée à la sanitaire rendra invalide la garantie.
- Nous recommandons fortement l'installation du produit par du personnel qualifié.
- Dans le cas de constructions neuves, il faut mettre en eau les WC, lavabos et bidets pour éviter que la robinetterie et les abattants ne s'oxydent ou ne jaunissent à cause de gaz corrosif. Nous recommandons de laisser un espace très aéré.
- Purger les tuyauteries avant l'installation.
- Vérifier le fonctionnement du mécanisme du réservoir du WC.
- Grâce à un entretien régulier, on peut éviter la formation de calcaire.
- Produits résiduels des toilettes et nettoyage peuvent abimer les pièces métalliques, en verre et/ou chromée des sanitaires, comme les charnières, enjoliveurs, boutons poussoirs, etc...



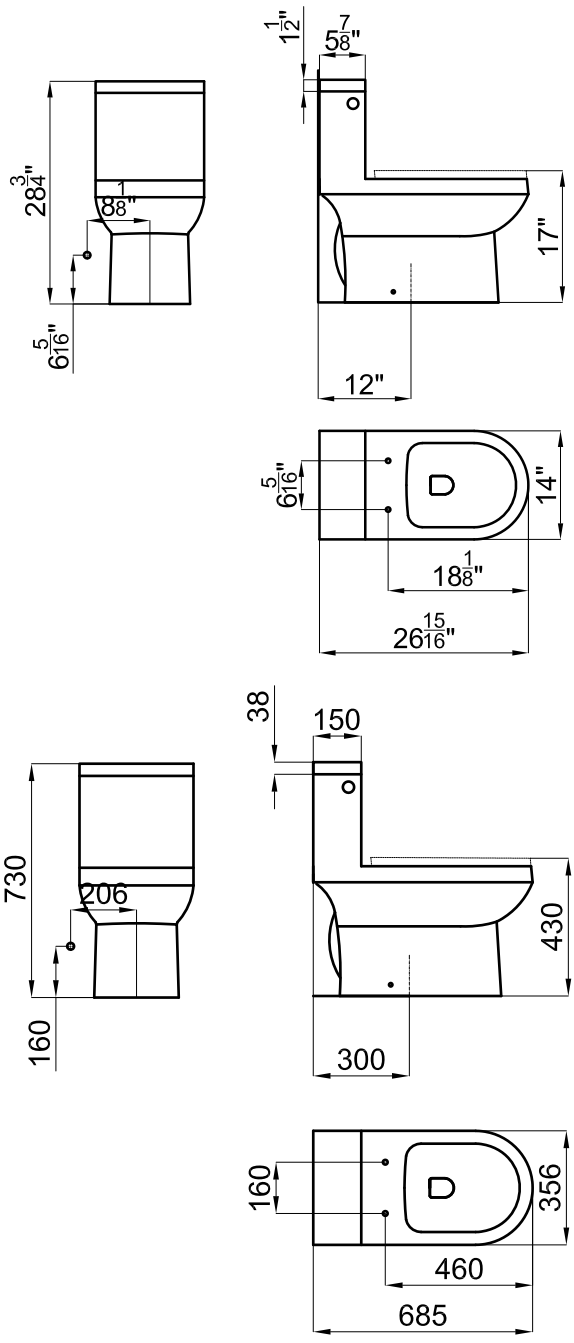

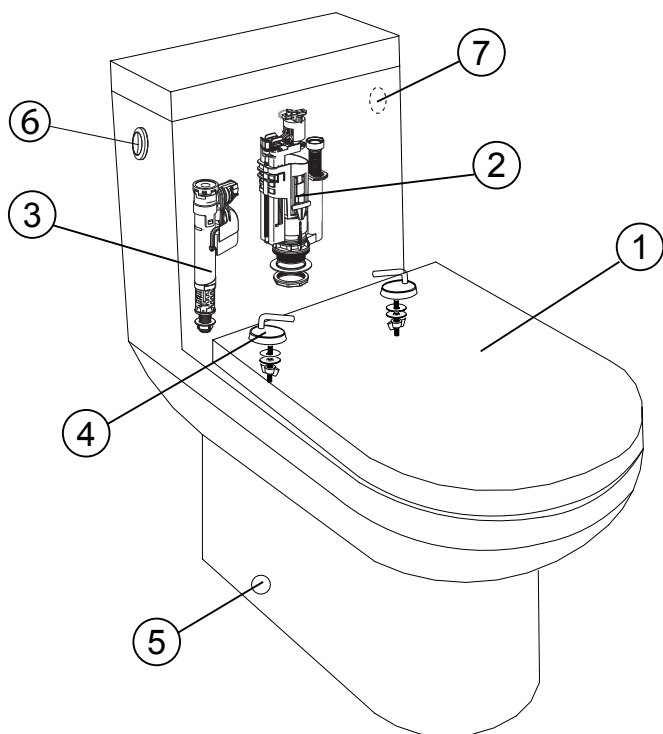

N°	CODE
1	100199403_N370170529
2	100169479_N370170522
3	100157730_N499817072
4	100199400_N370170528
5	100041212_N420150000
6	100213358_N499817155
7	100213403_N499817156



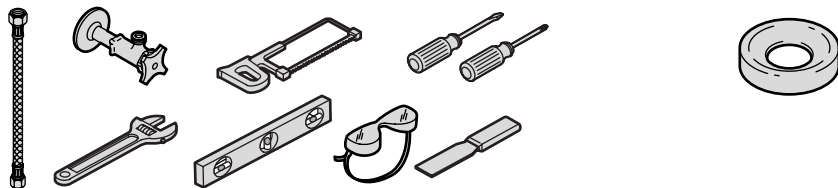

ATTENTION: INSTALLATION FITTINGS NOT INCLUDED.
ATENCIÓN: MATERIAL NECESARIO PARA LA INSTALACIÓN NO INCLUIDO.
ATTENTION: MATERIEL NECESSAIRE A L'INSTALLATION NON INCLUS.

1

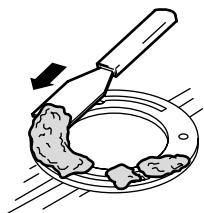

- If replacing a toilet, remove the old wax.
- Si va a reemplazar el inodoro, quite la cera vieja.
- En cas de remplacement du W.C., retirer l'ancienne cire.

2

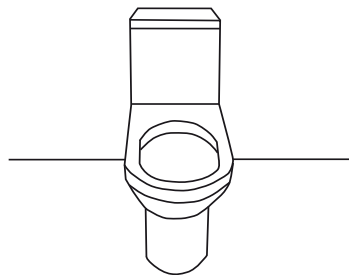

- Position the toilet into the correct place.
- Posicionar el inodoro en el lugar correcto.
- Posicioner la cuvette à sa place définitive.

3

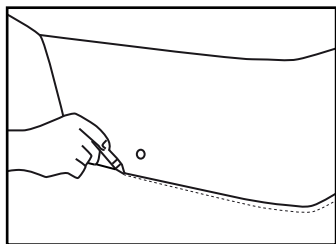

- Mark the foot print.
- Marcar el pie del inodoro.
- Marquer le contour de la cuvette.

4

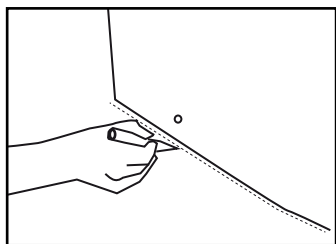

- Mark the fixing hole position on the floor.
- Marcar la posición de agujeros de fijación.
- Marquer la position des trous correspondant aux fixations.





5

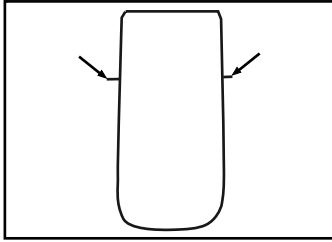

- Move the One-Piece, and you can see the fixing mark.
- Quitar el inodoro de su posición para ver las marcas de fijación.
- Retirer la cuvette de sa position pour voir les marques des fixations.

6a

- Install the plastic fixing.
- Instalar las escuadras de fijación.
- Installer les éléments de fixation en position correcte.

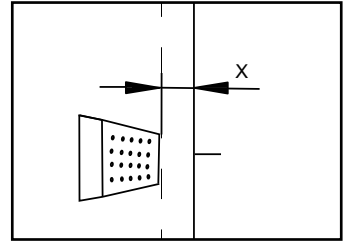

6b

- Verify that L-bracket will not interfere with the flange
- Vérifier que les fixations de la cuvette "L" n'interféré pas avec la bride de toilette
- Verifique que las fijaciones tipo "L" no interfieran con la brida de piso

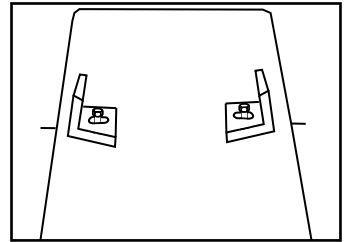

7

Wax Seal
Sello de cera
Joint en cire

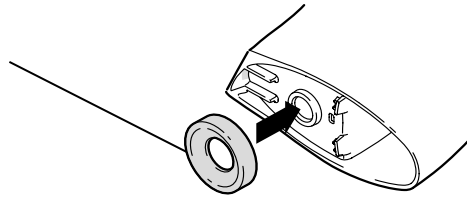

8

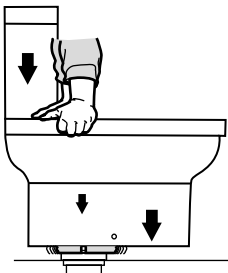

Do not move after placement!
Watertight seal may be broken!
¡No mueva después de colocar! ¡Se puede romper el sello hermético!
Ne pas bouger après avoir placé! Le joint d'étanchéité pourrait être cassé!

- Apply weight evenly.
- Aplique peso uniformemente.
- Appliquer du poids également.





9

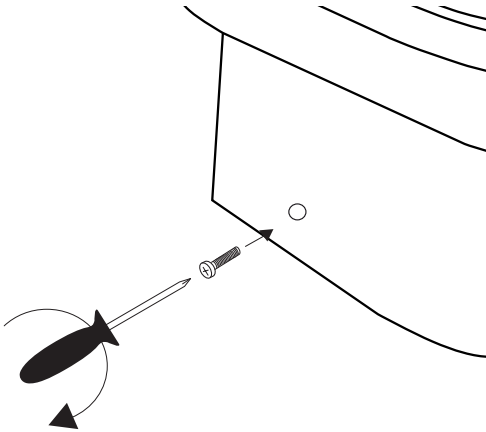

- Block the wc with the appropriate fixing kit.
- Fijar el inodoro con el kit de fijación suministrado.
- Fixer le wc avec le kit de fixation livré.

10

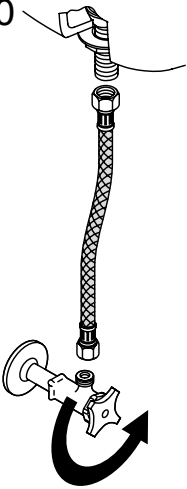

11

Mechanism adjusted to flush volume of 1.6 and 0.8 Gpf (6 and 3 lt).
Mecanismo ajustado a descargas de 1.6 y 0.8 Gpf (6 y 3 lt).
Mecanisme regle aux chasses 1.6 and 0.8 Gpf (6 et 3 lt).

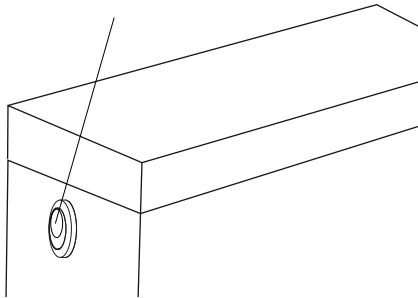

12

- Install the tank lid and the seat.
- Instale la tapa del tanque y el asiento.
- Installer le couvercle du réservoir et le siège.

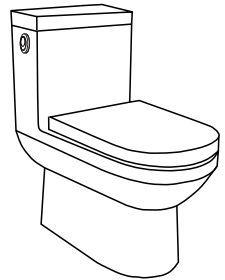

- Connect supply and turn on the water.
- Conecte el suministro y abra el agua.
- Connecter l'alimentation et ouvrir l'eau.

13

- Caulk around base (neutral anti-moisture silicone must be used)
- Appliquer du mastic autour de la base. (avec silicone neutre)
- Aplique sellador en la base del inodoro (usar silicona neutra anti-humedad)

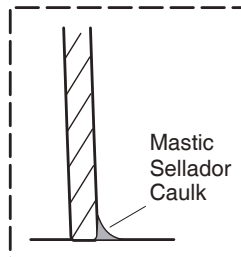

Mastic
Sellador
Caulk

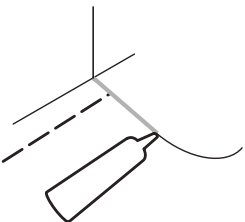

Flush several times and check for leaks.
Do not overtighten!

Accione la descarga varias veces y verifique que no haya fugas.
¡No apriete demasiado!

Purger plusieurs fois et vérifier s'il y a des fuites.
Ne pas trop serrer!



PORCELANOSA BATHROOMS



www.noken.com

Para consultar la garantía u otra información relativa a este producto, visitar nuestra web:
For a warranty or other information on this product, visit our Web address:
Pour obtenir une garantie ou d'autres informations sur ce produit, visitez notre site web
Para garantia ou outras informações sobre este produto, visite o nosso site

