



100171058_N369225491



100171074_N369225492



100171066_N369225488



100171084_N369225490

noken
PORCELANOSA BATHROOMS

Carretera CV-20 km.2 · 12540 Vila-real · Castellón · Spain
Tel: +34 964 50 64 50 - Fax: +34 964 50 67 93
e-mail: noken@noken.com · www.noken.com

URBAN C



Lea atentamente estas instrucciones antes de comenzar la instalación.

- Compruebe el producto por si faltasen piezas o estuviesen dañadas.
- Cualquier alteración que se realice al sanitario invalidaría la garantía.
- Le recomendamos la instalación por parte de personal cualificado.
- En nuevas construcciones se deben llenar los sifones de inodoros, lavabos y bidets de agua para evitar que la grifería y los asientos se oxiden o amarilleen por el efecto de la subida de gases corrosivos. Se recomienda que el espacio esté muy aireado.
- Purgar las tuberías antes de la instalación.
- Compruebe el funcionamiento del mecanismo de la cisterna del inodoro.
- Gracias a un cuidado periódico se puede evitar la formación de restos calcáreos.
- Residuos de productos de aseo y limpieza pueden dañar las piezas metálicas, cromadas y/o de vidrio de los sanitarios, como bisagras, embellecedores, pulsadores, etc...

- Please read these instructions carefully before starting installation and retain for future reference. Please leave these instructions with the end user.

- Remove all packaging and check the product for missing parts and damages before starting the installation.
- Any alterations made to this product and its fittings may infringe the water regulations and will invalidate the guarantee.
- We strongly recommend the use of a qualified and registered plumber.
- In new buildings it is recommended to water fill the traps to ensure toxic gases do not corrode the surface of the taps and toilet seats. It is recommended that the room is well ventilated.
- Thoroughly flush through all pipe work prior to the installation of terminal appliances, e.g. Shower heads, taps, inlet valves etc.
- Factory fitted components such as inlet and outlet valves should be checked for position and tightness, they may have loosened in transit. Check the operation of the valves.
- Periodic cleaning and maintenance should be used to avoid the build up of damaging lime scale deposits.
- Bathroom harsh cleaning agent residuals may damage components made of metal, glass and/or chromed parts such as, seat hinges, trim plates, push buttons, etc...





- Lire attentivement cette notice avant de commencer l'installation
- Vérifier si certaines pièces sont manquantes o abîmées.
- Toute altération qui sera effectuée à la sanitaire rendra invalide la garantie.
- Nous recommandons fortement l'installation du produit par du personnel qualifié.
- Dans le cas de constructions neuves, il faut mettre en eau les WC, lavabos et bidets pour éviter que la robinetterie et les abattants ne s'oxydent ou ne jaunissent à cause de gaz corrosif. Nous recommandons de laisser un espace très aéré.
- Purger les tuyauteries avant l'installation.
- Vérifier le fonctionnement du mécanisme du réservoir du WC.
- Grâce à un entretien régulier, on peut éviter la formation de calcaire.
- Produits résiduels des toilettes et nettoyage peuvent abîmer les pièces métalliques, en verre et/ou chromée des sanitaires, comme les charnières, enjoliveurs, boutons poussoirs, etc...

- Leia atentamente as instruções antes de começar a instalação.
- Verifique se o produto se encontra em bom estado.
- Qualquer alteração que se realize no sanitário perde a garantia.
- Aconselhamos que a instalação seja feita por um profissional qualificado.
- Em novas construções, após a colocação da sanita, bidé e lavatório, os sifões deverão ser preenchidos com água para evitar o aparecimento de oxidações nas torneiras e tampas de sanita pelo efeito da subida de gases corrosivos pelos tubos.
- Recomenda-se que o espaço esteja muito arejado.
- Testar a tubaria antes da instalação.
- Testar o funcionamento do mecanismo do tanque de descarga da sanita.
- Mantendo um cuidado periódico poderá evitar a formação de calcários.
- Resíduos de produtos de limpeza podem danificar as peças de metal, cromado ou vidro de sanitários, tais como dobradiças, embelezadores, botões, etc....



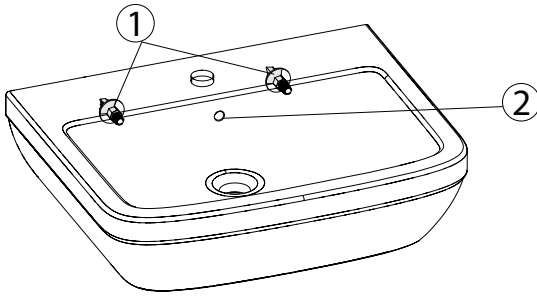

| | |
|---|----------------------|
| 1 | 100041225_N421040000 |
| 2 | 100041232_N421270001 |

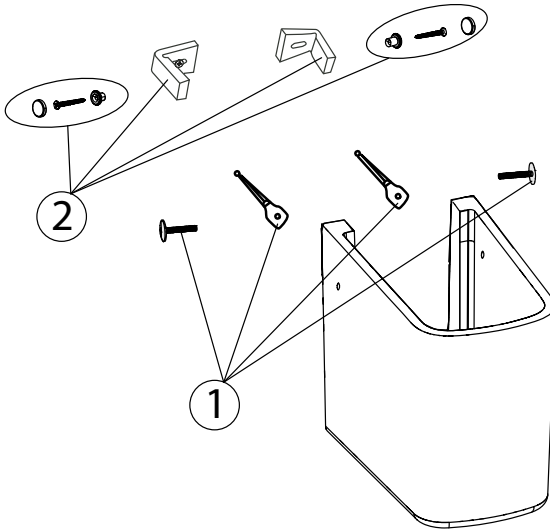

| 100171074_N369225492 | | |
|----------------------|----------------------|----------------------|
| | A01 | B01 |
| 1 | 100077249_N499816855 | - |
| 2 | - | 100041212_N420150000 |



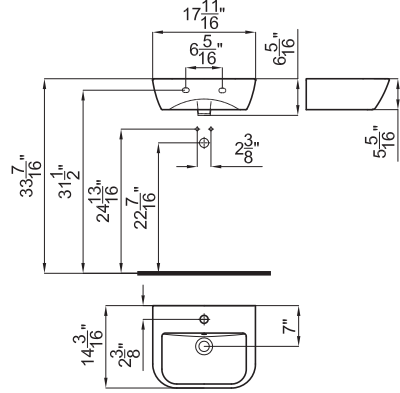
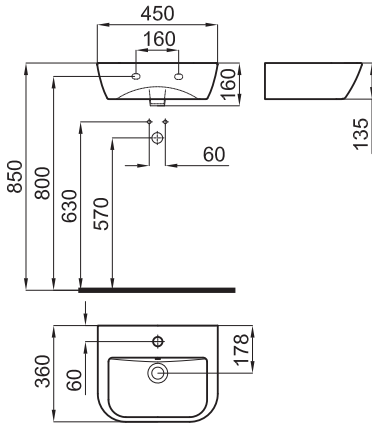

100171084_N369225490

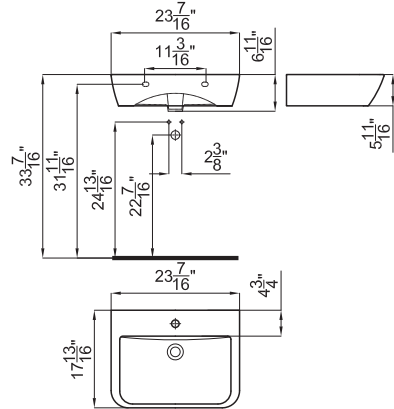
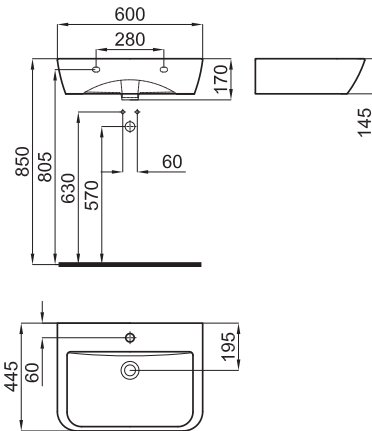

100171066_N369225488



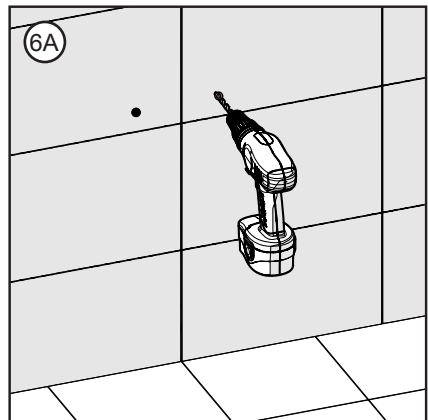
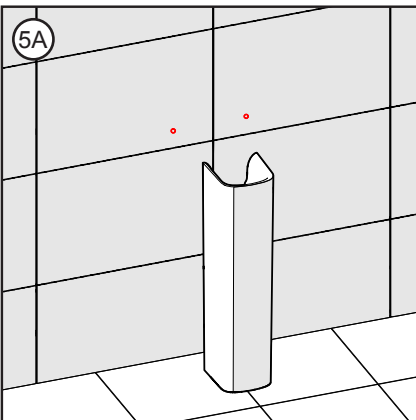
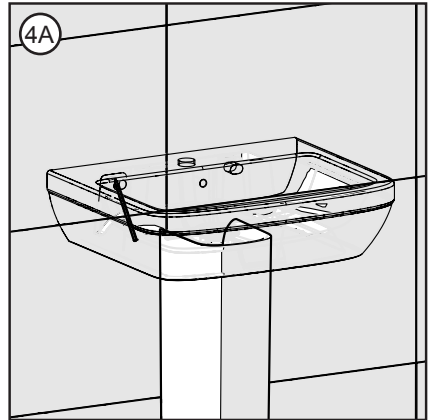
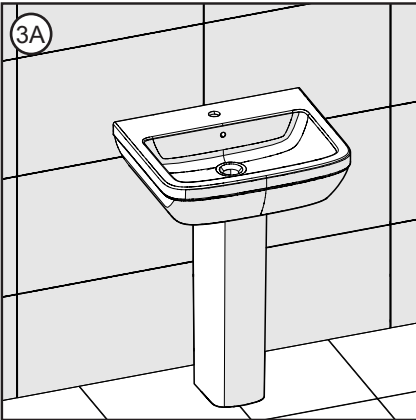
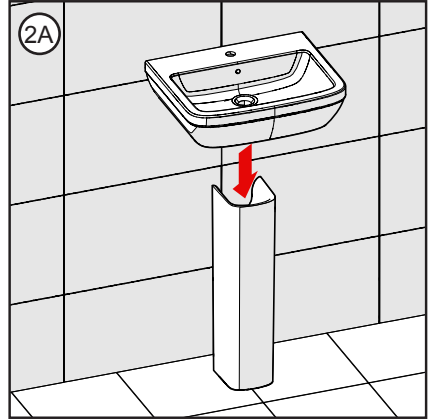
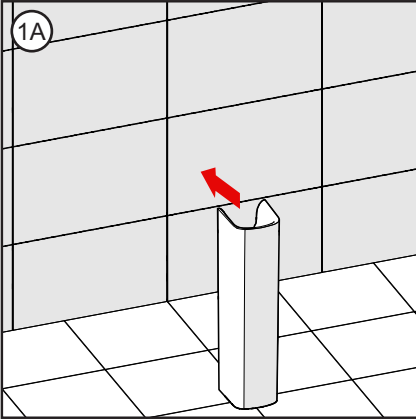
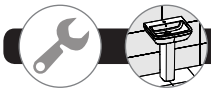

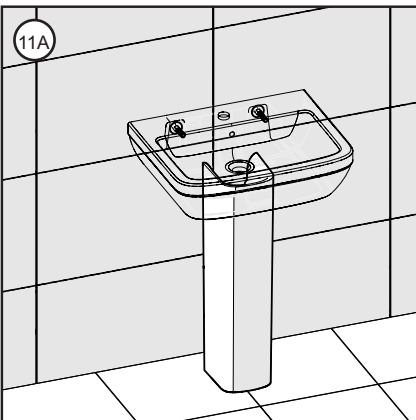
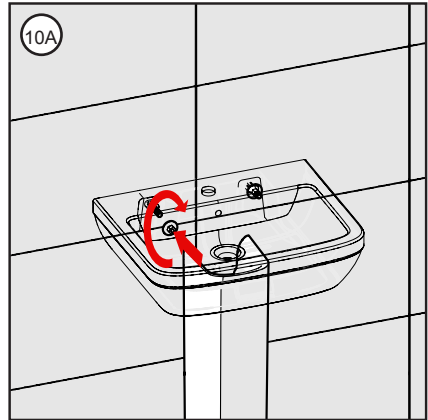
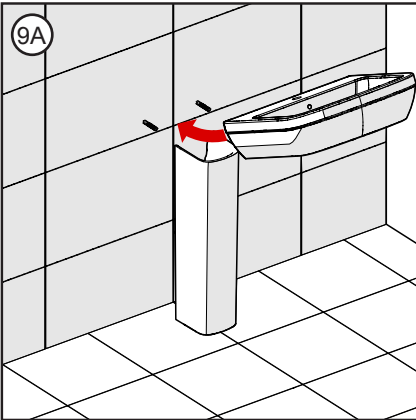
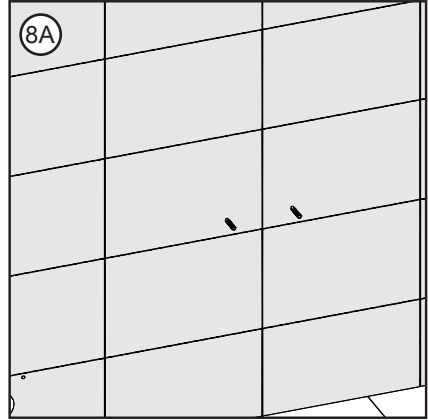
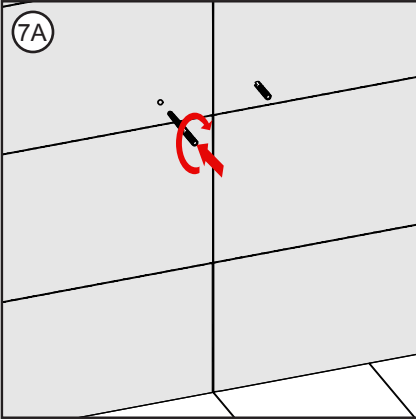



A01

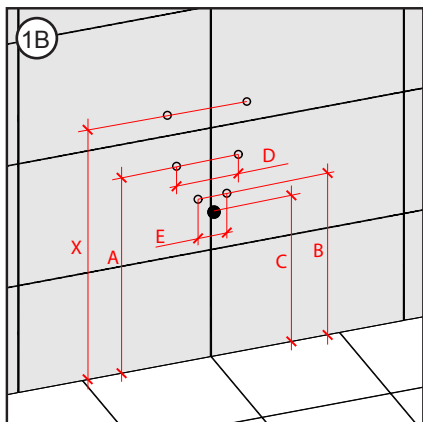

| | 60 | 45 |
|---|----|----|
| X | | |
| A | | |
| B | | |
| C | | |
| D | | |
| E | | |

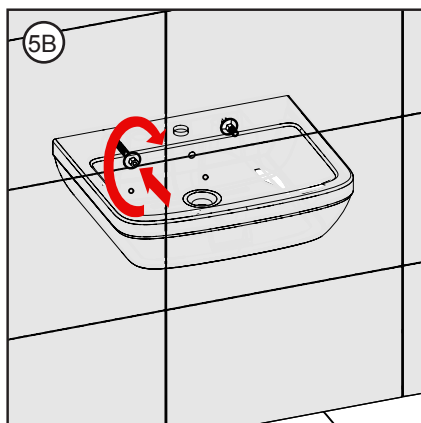
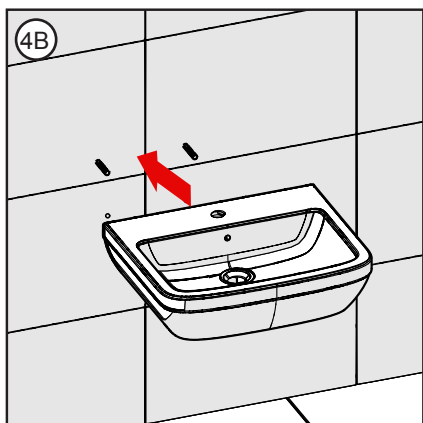
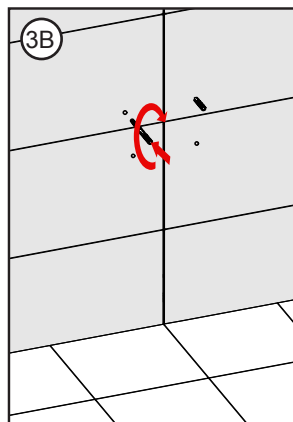
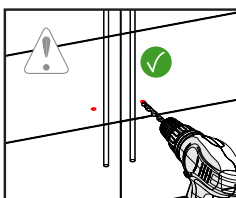
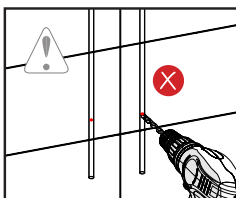
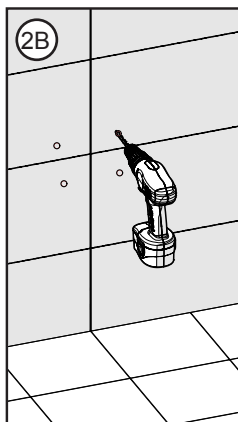

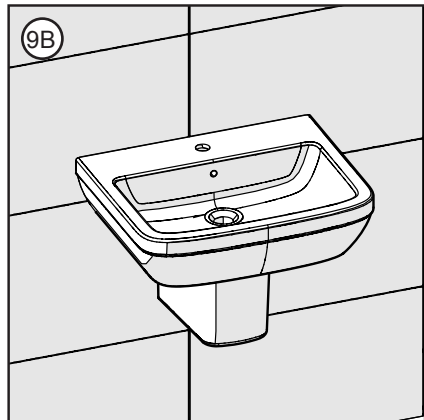
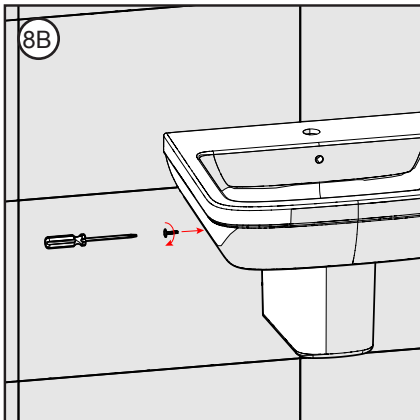
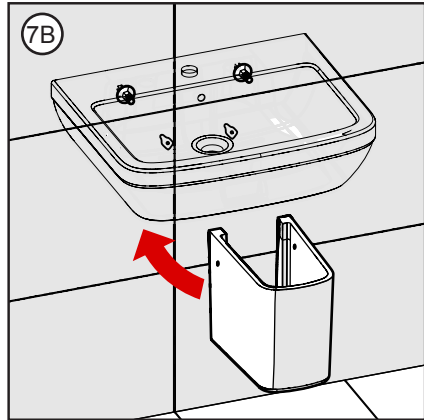
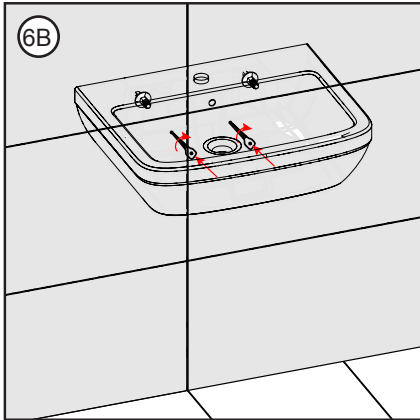



B01

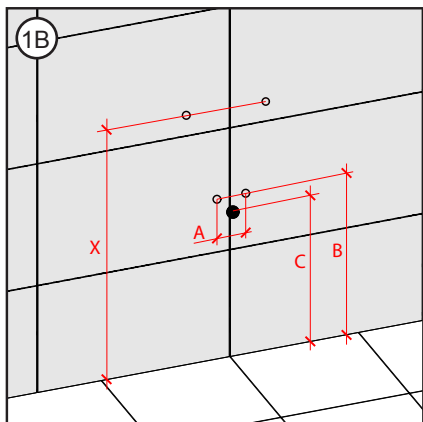

| | 60 | 45 |
|---|----|----|
| X | | |
| A | | |
| B | | |
| C | | |

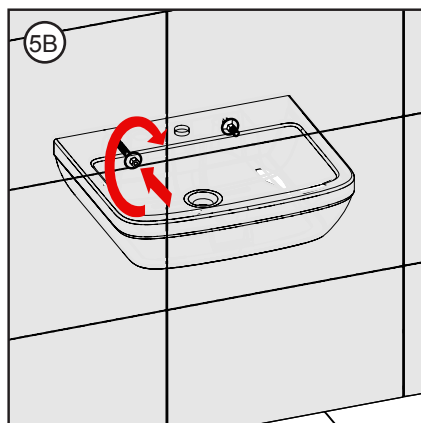
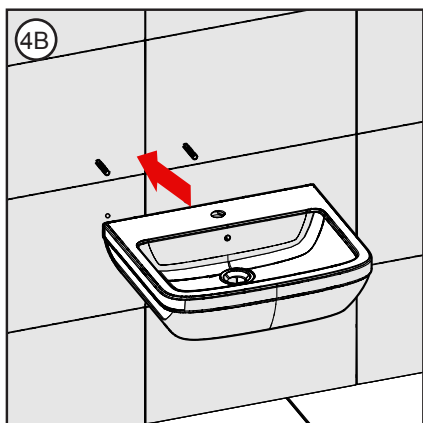
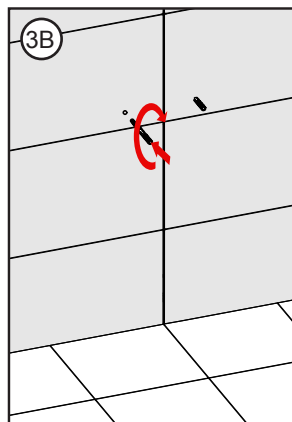
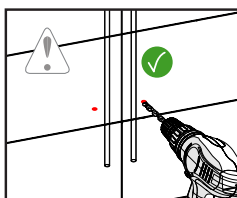
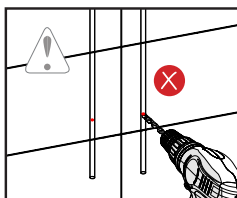
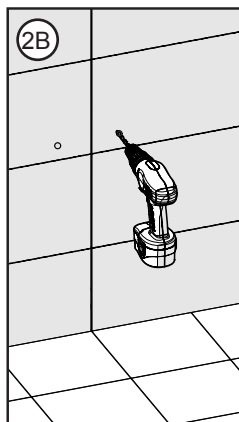

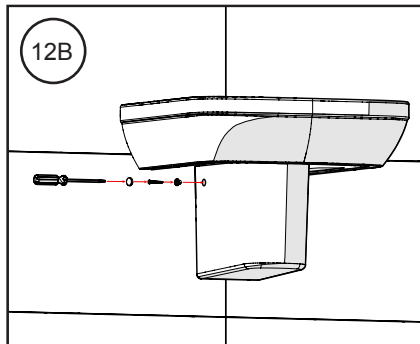
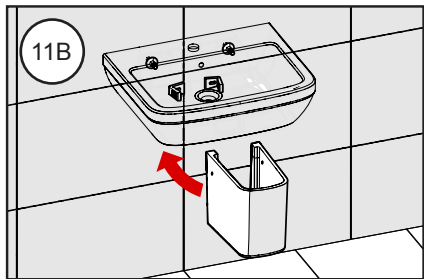
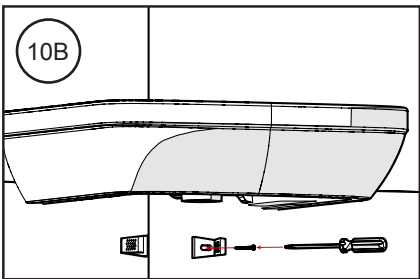
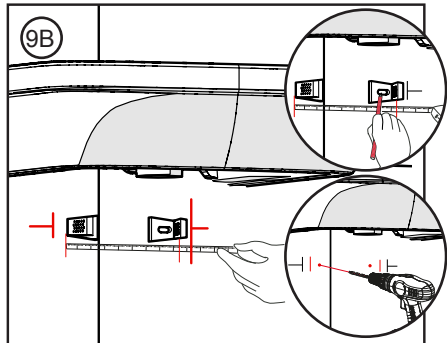
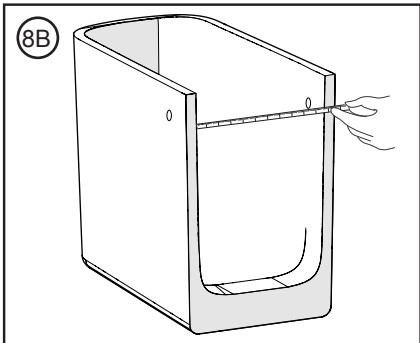
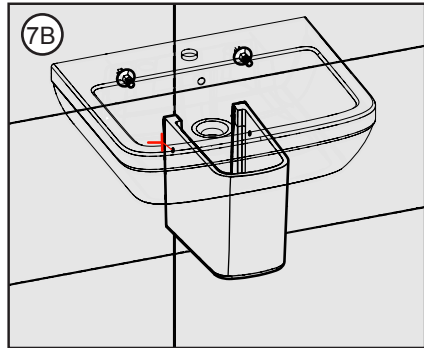
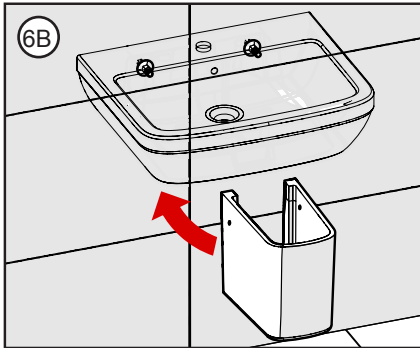



www.noken.com

PORCELANOSA BATHROOMS

