

○ 100162417_N710001201

● 100171640_N710001203

noken
PORCELANOSA Grupo

Ctra. Villarreal-Puebla de Arenoso (CV-20) km. 2
P.O./box 372 - 12540 Villarreal (Castellón) Spain

Tel: +34 964 50 64 50 _ Fax: +34 964 50 67 92 _ www.noken.com _ noken@noken.com

CHELSEA



Lea atentamente estas instrucciones antes de comenzar la instalación.

- Compruebe el producto por si faltasen piezas o estuviesen dañadas.
- Cualquier alteración que se realice al producto invalidaría la garantía.
- Le recomendamos la instalación por parte de personal cualificado.
- En nuevas construcciones se deben llenar de agua los sifones de inodoros, lavabos, bidets y bañeras, para evitar que la grifería, asientos u otros accesorios se oxiden o amarilleen por el efecto de la subida de gases corrosivos. Se recomienda que el espacio esté muy aireado.
- Purgar las tuberías antes de la instalación.
- Compruebe el funcionamiento de los mecanismos.
- Gracias a un cuidado periódico se puede evitar la formación de restos calcáreos.
- Residuos de productos de aseo y limpieza pueden dañar las piezas metálicas, cromadas y/o de vidrio de los productos, como bisagras, embelecadores, pulsadores, componentes desagüe, etc...
- Para la limpieza de la bañera, utilizar jabones líquidos y agua con paños o esponjas no abrasivos. **Nunca utilizar para la limpieza de la bañera acrílica productos disolventes (acetona, alcohol, etc.) ni detergentes o paños abrasivos que dañarían la superficie de la misma.** Para dar brillo a la bañera, utilizar un pulimento de los habituales en el mercado.
- Para la limpieza de las partes metálicas, utilizar un paño suave para no rayar los distintos acabados metálicos. No limpiar con agentes corrosivos.
- **Revisar el material a su llegada, y si se advierte algún desperfecto reclamar de inmediato al transportista.**
- **Verificar el producto, y el perfecto estado de sus componentes antes de realizar la instalación. Si se advierte algún defecto, proceder a la reclamación antes de la instalación.**

- Please read these instructions carefully before starting installation and retain for future reference. Please leave these instructions with the end user.
- Remove all packaging and check the product for missing parts and damages before starting the installation.
- Any alterations made to this product and its fittings may infringe the water regulations and will invalidate the guarantee.
- We strongly recommend the use of a qualified and registered plumber.
- In new buildings it is recommended to water fill the traps to ensure toxic gases do not corrode the surface of the taps, toilet seats, bathtub and other elements in the bathroom. It is recommended that the room is well ventilated.
- Thoroughly flush through all pipe work prior to the installation of terminal appliances, e.g. Shower heads, taps, inlet valves etc.
- Factory fitted components such as inlet and outlet valves should be checked for position and tightness, they may have loosened in transit. Check the operation of the valves.
- Periodic cleaning and maintenance should be used to avoid the build up of damaging lime scale deposits.
- Bathroom harsh cleaning agent residuals may damage components made of metal, glass and/or chromed parts such as, seat hinges, trim plates, push buttons, drain parts, etc...
- Clean the bathtub with liquid soap and water and soft, non-abrasive cloths or sponges. **Never clean the bath with acrylic solvents (acetone, alcohol, etc.), Detergents, or abrasive cloths as these could damage its finish.** To keep your bath looking shiny, use a standard household polish.
- Use a soft cloth to clean any metal parts and leave them shiny and scratch free. Do not clean the metal with corrosive products.
- **Check the goods upon arrival, if any damage is detected notify the carrier immediately.**
- **Before proceeding with the installation, check that full product supplied and their parts are in perfect condition. If a defect is noticed, proceed with the claim before installing.**

- Lire attentivement cette notice avant de commencer l'installation
- Vérifier si certaines pièces sont manquantes o abimées.
- Toute altération qui sera effectuée au produit rendra invalide la garantie.
- Nous recommandons fortement l'installation du produit par du personnel qualifié.
- Dans le cas de constructions neuves, il faut mettre en eau les WC, lavabos et bidets pour éviter que la robinetterie, les abattants, baignoires et autres éléments de bain ne s'oxydent ou ne jaunissent à cause de gaz corrosif. Nous recommandons de laisser un espace très aéré.
- Purgar les tuyauteries avant l'installation.
- Vérifier le fonctionnement du mécanisme.
- Grâce à un entretien régulier, on peut éviter la formation de calcaire.
- Produits résiduels des toilettes et nettoyage peuvent abimer les pièces métalliques, en verre et/ou des parties chrome, comme les charnières, enjoliveurs, boutons poussoirs, composants de vidage, etc...
- Pour le nettoyage de la baignoire, employer des savons liquides et de l'eau, et utiliser des éponges ou linges non abrasifs. **Pour nettoyer la baignoire en acrylique, n'utiliser en aucun cas des produits solvants (acétone, alcool, etc.), ni des détergents ou des linges abrasifs, ce qui endommagerait la surface de la baignoire.** Pour faire briller la baignoire, employer un produit de lustrage ordinaire du commerce.
- Pour nettoyer les éléments métalliques, utiliser un linge doux de manière à ne pas rayer les différentes finitions métalliques. Ne nettoyez pas l'anneau de métal avec des produits corrosifs.
- **Vérifiez les marchandises à l'arrivée, si un dommage est détecté adresser immédiatement une réclamation au transporteur.**
- **Avant de procéder à l'installation, vérifier que le produit complet fourni et leurs pièces sont en parfait état. Si un défaut est remarqué, suite à la réclamation avant l'installation.**

- Leia atentamente as instruções antes de começar a instalação.
- Verifique se o produto se encontra em bom estado.
- Qualquer alteração que se realize no produto perde a garantia.
- Aconselhamos que a instalação seja feita por um profissional qualificado.
- Em novas construções, após a colocação da sanita, bidé, lavatório e banheira, os sifões deverão ser preenchidos com água para evitar o aparecimento de oxidações nas torneiras, tampas de sanita e outros elementos do banheiro, pelo efeito da subida de gases corrosivos pelos tubos. Recomenda-se que o espaço esteja muito arejado.
- Testar a tubaria antes da instalação.
- Testar o funcionamento dos mecanismos.
- Mantendo um cuidado periódico poderá evitar a formação de calcários.
- Resíduos de produtos de limpeza podem danificar as peças de metal, cromado ou vidro de produtos, tais como dobradiças, embelecadores, botões, sifões, etc...
- Para limpar a banheira, use sabão líquido e água com um pano não abrasivo ou esponja. Nunca use para limpar, solventes acrílicos para banheira (acetona, álcool, etc.) ou detergentes e/ou panos abrasivos que podem danificar a superfície do mesmo. Para dar brilho, use um produto específico.
- Para limpar as peças de metal, use um pano macio para evitar riscar os acabamentos metálicos. Não utilizar produtos de limpeza corrosivos.
- **Verifique os bens no momento da chegada, se o dano for detectado, imediatamente apresentar uma reclamação ao transportador.**
- **Antes de instalar, verifique se o produto fornecido completo e peças estão em perfeitas condições. Se um defeito for observado, na sequência da queixa antes da instalação.**



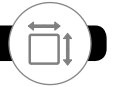

mm

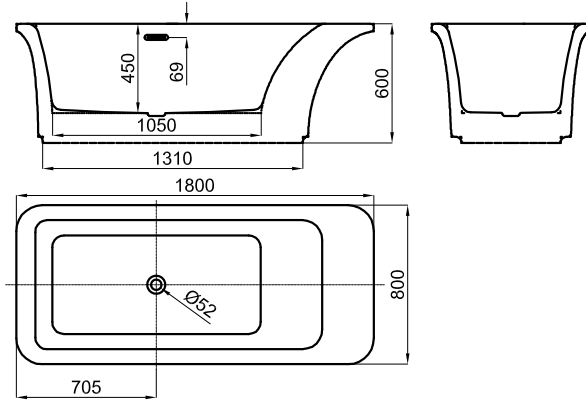

INCH

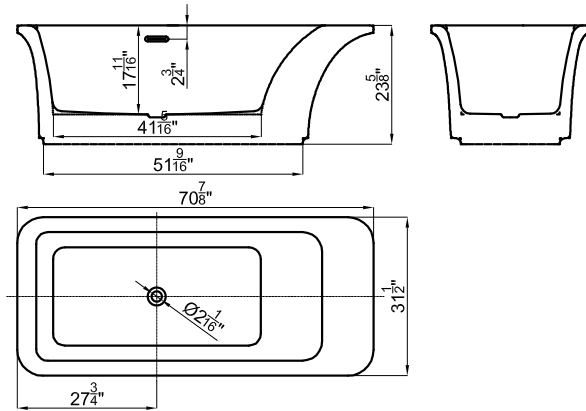

			CONIC	
			Kg/Lbs	Kg/Lbs
<input type="radio"/> 100162417 N710001201 <input type="radio"/> 100171640 N710001203	L	1850 // 72_13/16"	52 kg // 114 Lbs	64 kg // 141 Lbs
	W	850 // 33_7/16"		
	H	640 // 25_3/16"		





1

NORTH-AMERICA

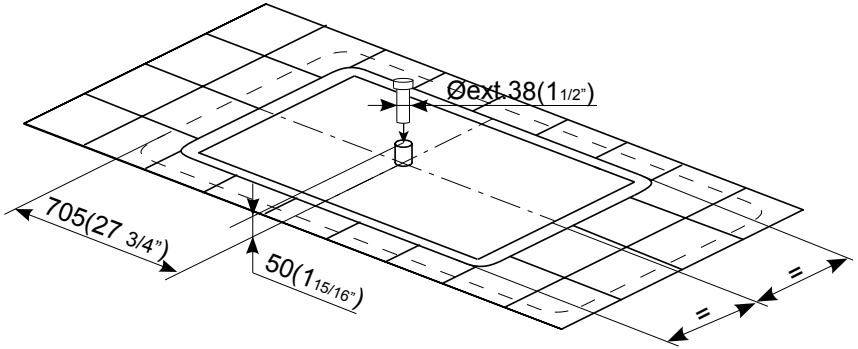

INT

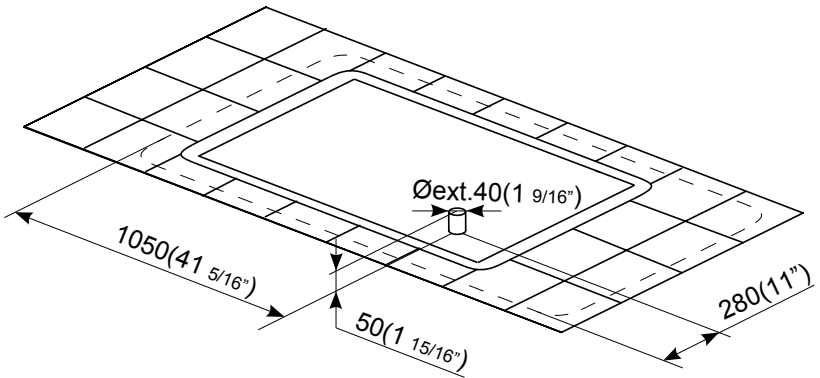



2

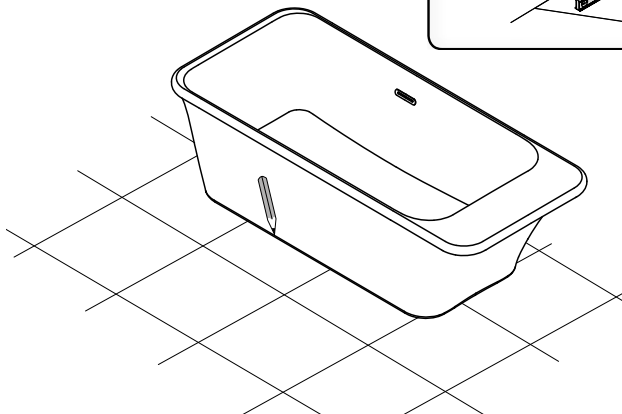
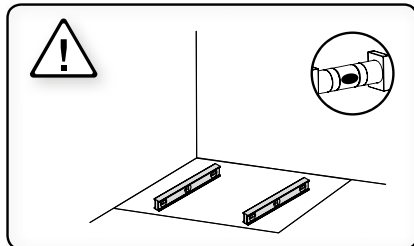

3

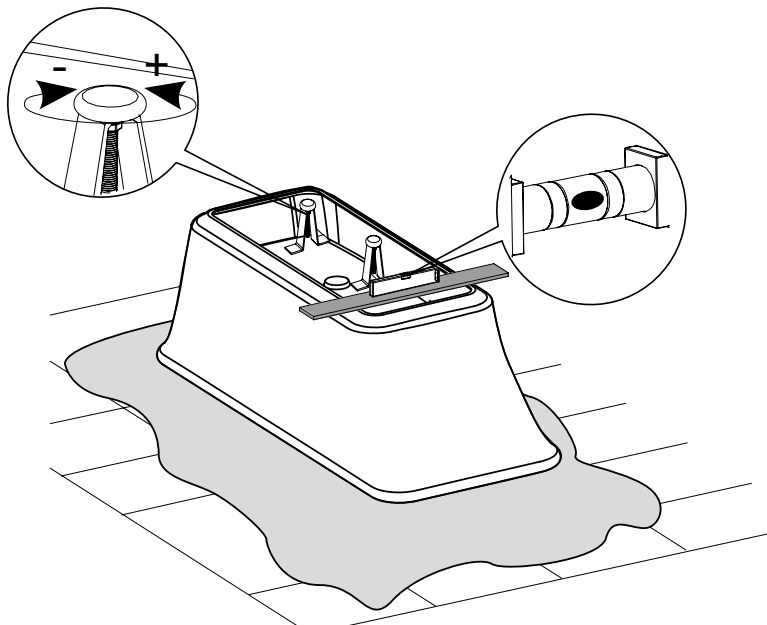

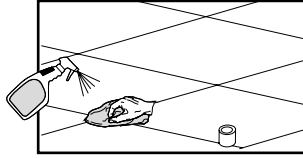

4

Northamerica

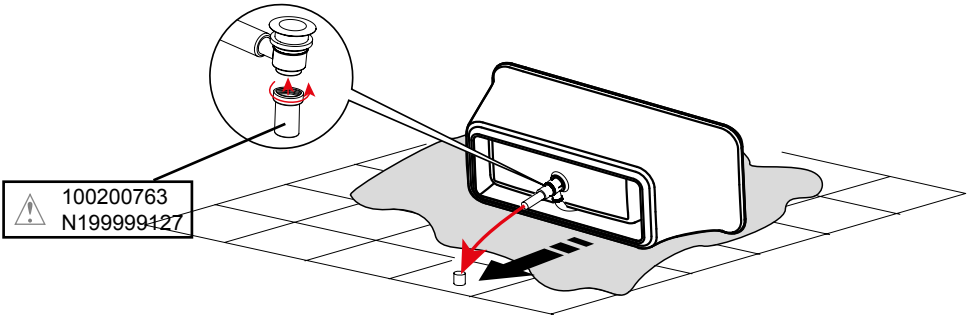

4

INT

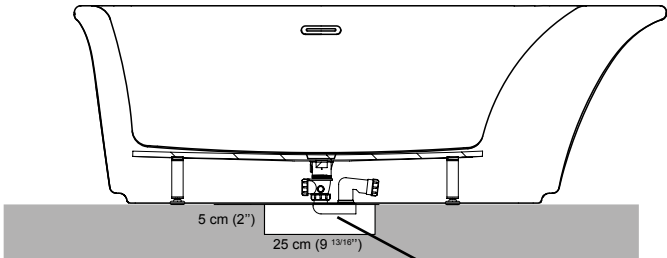

100158208
N790001657

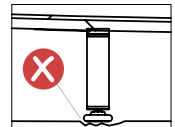
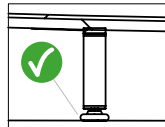
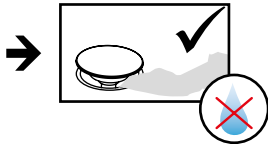
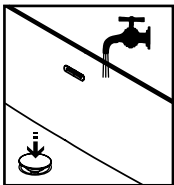





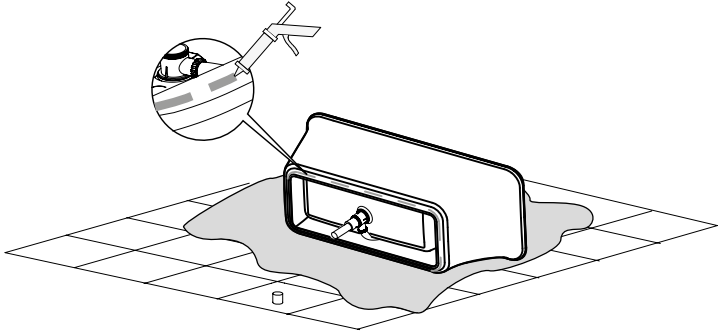

5

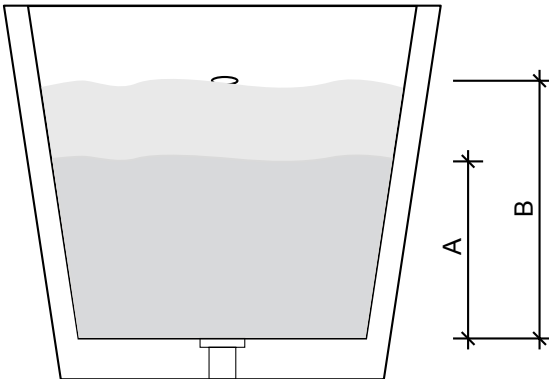
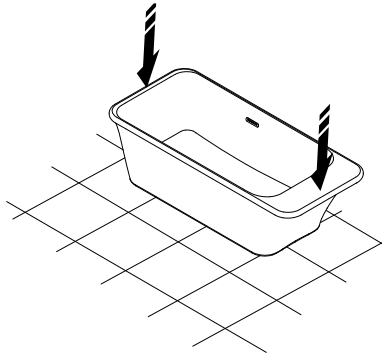

6



	+	
	205 Kg 452 Lbs	153 L
	262 Kg 578 Lbs	210 L





Las bañeras Noken Design han sido fabricadas con elevadas exigencias y pensando, en todo momento, en la satisfacción del usuario final. Las bañeras son montadas y puestas a prueba, una a una, superando rigurosos controles técnicos y de seguridad, en nuestras instalaciones, para verificar su correcto funcionamiento antes de salir de fábrica.

La instalación de fontanería debe hacerse de acuerdo con la reglamentación vigente en cada país para las instalaciones de fontanería en edificios.

La instalación debe ser realizada exclusivamente por un instalador cualificado.

Asimismo Noken Design S.A. declina toda responsabilidad en caso de una instalación incorrecta.

La máxima dureza del agua aconsejable para esta gama de bañeras es de 18°TH (Grados franceses) / 13°e (Grados ingleses).

Las bañeras no han sido diseñadas para tratamientos con algas, barro, aguas marinas, etc.

Cuando está húmeda, la superficie de la mayor parte de las bañeras presenta un aumento del riesgo potencial de deslizamiento. Esto es más significativo cuando se utiliza jabón, champú, aceites para el baño y otros productos similares. Es importante que los usuarios de las bañeras sean conscientes de esto.

Nota: Verificar, antes de realizar la instalación, el perfecto estado de las piezas. En caso contrario, reclamar al transportista.

Noken Design baths are manufactured to the strictest standards to ensure quality performance and full customer satisfaction at all times.

Each and every one of our baths is assembled and tested before leaving the factory.

All plumbing installation work should be effected in compliance with national regulations concerning plumbing installations in buildings.

The system must only be installed by qualified professionals.

Noken Design S.A. declines all responsibility in the event of improper installation.

The maximum recommended water hardness for the range of baths is 18°TH (French degree of hardness) / 13°e (English degree of hardness).

The baths are not designed to be used for seaweed, mud or seawater treatments, etc.

There is an increased risk of falls when the surface of most baths is wet and therefore slippery. This is particularly true when soap, shampoo, bath oils and other similar products are used. Users of baths must be aware of this fact.

NB: Before proceeding with the installation, check that all the parts supplied are in perfect condition. Notify the carrier immediately if this is not the case.

Les baignoires Noken Design sont fabriquées selon des critères de qualité très exigeants afin de garantir la satisfaction de l'utilisateur final.

Les baignoires sont montées et testées une par une dans nos installations, et soumises à de rigoureux contrôles techniques et de sécurité, pour nous assurer qu'elles fonctionnent correctement avant d'abandonner l'usine.

Les travaux de plomberie doivent être effectués conformément aux réglementations en vigueur dans chaque pays pour les installations de plomberie dans les bâtiments.

L'installation ne peut être réalisée que par un installateur qualifié uniquement.

Noken Design S.A. décline toute responsabilité en cas d'installation incorrecte.

La dureté maximale recommandée de l'eau pour la gamme de baignoires est de 18°TH (Degrés français) / 13°e (Degrés anglais).

Les baignoires n'ont pas été conçues pour les traitements aux algues, aux boues, aux eaux marines, etc.

Lorsqu'elle est humide, la surface de la plupart des baignoires présente un risque potentiel accru de dérapage. Ce risque est plus important en cas d'utilisation de savons, de shampoings, d'huiles pour le bain et d'autres produits similaires. Il est très important que les utilisateurs des baignoires en soient conscients.

Remarque: S'assurer que les pièces de la baignoire sont en parfait état avant de procéder à son installation. Si ce n'est pas le cas, adresser une réclamation au transporteur.

Banheiras Noken Design foram fabricadas com elevadas exigências e a pensar em todos os momentos e na satisfação do cliente final.

As banheiras são montadas e testadas uma a uma, superando testes técnicos e de segurança nas nossas instalações, para verificar funcionamento adequado antes de sair da fábrica.

A instalação de canalização deve estar de acordo com as normas vigentes em cada país, para a instalação de pichelaria em edifícios.

A instalação só deve ser realizada por um instalador qualificado.

Noken Design, S.A. declina qualquer responsabilidade por instalação incorreta.

A dureza máxima recomendada de água para essa gama de banheiras é 18°TH (graus franceses) / 13°e (Gaus britânicos).

As banheiras não são projetadas para tratamentos de algas, lama, água do mar, etc.

Quando molhada, a superfície da maior parte dos banhos apresenta potencial risco de escorregamento. Isto acontece com mais frequência quando se usa sabonete, shampoo, óleos de banho e produtos similares. É importante que os usuários dos banhos sejam conscientes disso.

Nota: Verifique antes de instalar as peças. Caso contrário reclame com a transportadora.

